



---

## Two-Speed Conventional Reel

---

Instructions For Use

Qualia Corporation

Contact Us

Parts List, Reel Schematic

396B 7th St., #164

Phone: 415-382-1099

Novato, CA 94945, USA

Email: [qualia@ix.netcom.com](mailto:qualia@ix.netcom.com)

### Prepare yourself for a pleasant surprise

This Advanz Conventional Reel is full of features you'd usually pay much more to own:

- The CNC billet-machined main frame provides the maximum possible frame rigidity.
- Cold forged aluminum sideplates match the mainframe for greatest strength and provide the best parts alignment.
- A CNC billet-machined spool ensures maximum material consistency and strongest line support.
- All stainless steel gearing provides superior strength plus corrosion and wear resistance.
- A stainless steel foot means that your reel will always have the strongest possible attachment to your rod.
- The cold-forged adjustable aluminum lever drag will give you years of dependable use.
- An ON/OFF spool clicker broadcasts an audible alarm when line is being stripped from the reel.
- A dual positive anti-reverse system means consistent, maximum stopping strength.
- The comfort-touch grip keeps your hand in the fight for hour after hour of hard fishing.

So what do these specifications do for you? Truth be told, they do nothing for you until you go fishing.

But when you do go fishing with this Advanz reel, you'll find that these features give you a chance to fight harder, fight longer and fight with less fatigue. While all reels have a limit of durability, we purposely over-designed the Advanz reels so that you can test your saltwater skills to the limit.

Fish hard. Fish safe. And have fun!

---

## **CARE AND MAINTENANCE**

---

While we have done everything possible to make your Advanz Conventional Reel the highest value available, it remains a finely tuned piece of equipment that requires a minimal amount of care and maintenance. We congratulate you on your excellent choice of fishing equipment and recommend that you review the following maintenance suggestions; for the longest lasting pleasure with your tackle, we suggest adding these simple procedures to your regular fishing regimen.

---

### **BEFORE EACH FISHING TRIP**

---

Carefully consider your choice of equipment. We all know that we cannot reasonably expect a small sports car to carry the local football team to its games; every car is designed for a certain purpose. In the same way, all fishing equipment is designed for a limited set of circumstances. For the greatest fishing performance, your choice of equipment should consider the type of fishing for which it will be used.

- Check that the line on your reel is fresh. Most lines tend to stretch and degrade over time and lose both their pull test and knot strength.
  - Check that the reel has been cleaned, greased and stored properly with the drag slightly loosened.
  - Check that the rod guides are all in good condition (no broken or loose rings).
  - Check that the rod seat holds the reel securely in place
- 

### **AFTER EACH FISHING TRIP**

---

Clean both your rod and reel, lubricate your reel carefully, and back the drag off slightly before storing your reel. This is probably the most important recommendation for maintaining the longest working life of your reel and rod.

It is not necessary to submerge your reel in fresh water or hit it with a high-pressure blast of water. Few reels are dragged through mud or keel hauled behind a boat; therefore gently spraying your reel and rod with clean water after each fishing excursion and wiping them off thoroughly with a soft towel will take care of most cleaning requirements.

After cleaning, a light coating of a thin, high grade oil on all moving parts is recommended. While we strongly recommend using a competent service technician for maintaining the insides of your reel, we know that many folks who fish enjoy disassembling their reels both for fun and for maintenance purposes. To assist those who do disassemble their reel, the attached exploded drawing should help explain the parts and assembly of your Advanz Conventional Reel, and to help if ordering parts is required.

---

### **ONCE EACH SEASON**

---

If you properly maintain your reel and rod as recommended above, it is unlikely that you will ever need to send your reel in for service. Nonetheless, we recommend an occasional trip to a service center for a professional cleaning and service of your reel.

Service centers generally use better grades of grease and oil than most folks keep on hand, and it is very helpful to have a trained eye inspect your reel occasionally to make sure no unforeseen problems are developing.

If you follow the above recommendations, you should look forward to many enjoyable fishing experiences. Thank you again for your purchase of this outstanding Advanz Conventional Reel.

## PARTS SCHEMATIC

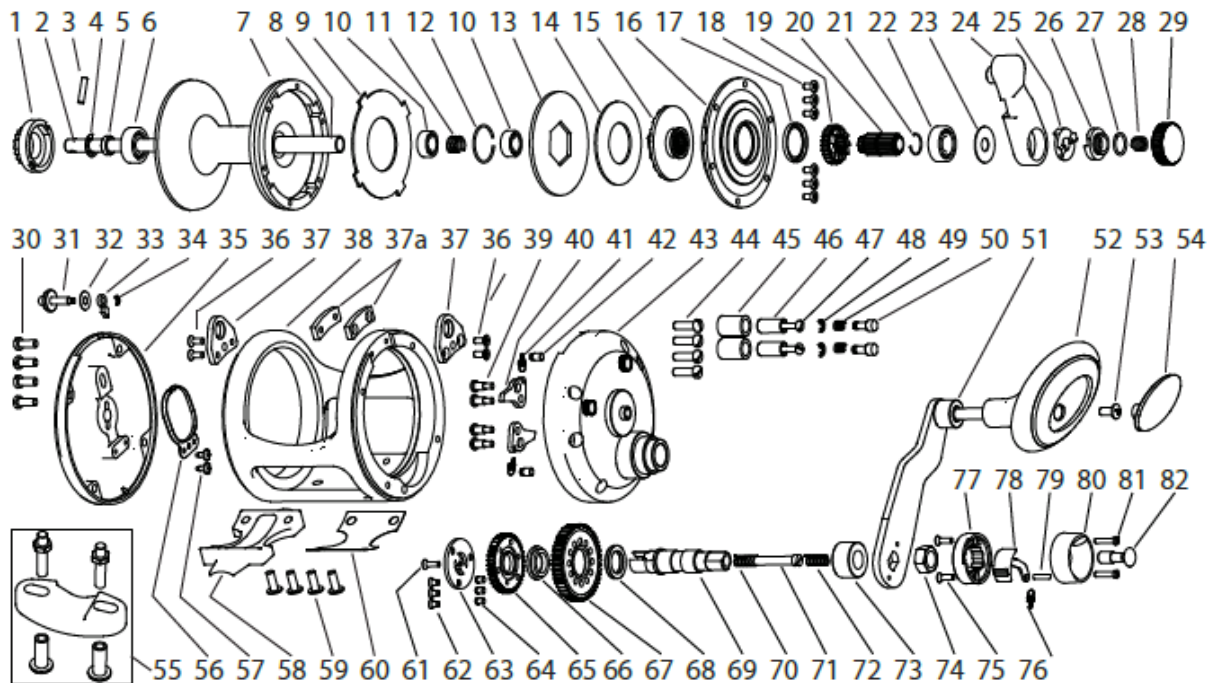

- |                           |                         |                              |
|---------------------------|-------------------------|------------------------------|
| 1. Clicker gear           | 29. Drag knob           | 56. Click pawl spring        |
| 2. Mainshaft              | 30. Left SP screw (4)   | 57. Spring screw (2)         |
| 3. Mainshaft pin          | 31. Clicker switch      | 58. Foot                     |
| 4. Bearing retainer clip  | 32. Switch shim         | 59. Foot screw (4)           |
| 5. Bearing bushing        | 33. Clicker pawl        | 60. Foot insulator           |
| 6. Bearing (7x19x6)       | 34. Pawl retainer clip  | 61. Shift core screw         |
| 7. Spool                  | 35. Left sideplate      | 62. Shift plate screw (3)    |
| 8. Mainshaft bushing      | 36. Lug screw (4)       | 63. Shift plate              |
| 9. Friction washer        | 37. Harness lug (2)     | 64. Gear pin (3)             |
| 10. Bearing (7x14x5)      | 37a. Lug hole plug (2)  | 65. Slow speed main gear     |
| 11. Drag coil spring      | 38. Mainframe           | 66. Main gear nut            |
| 12. Hub retainer          | 39. A/R pawl screw (4)  | 67. High speed main gear     |
| 13. Pressure plate        | 40. A/R pawl (2)        | 68. Main gear shim           |
| 14. Spring washer         | 41. A/R pawl spring (2) | 69. Drive shaft              |
| 15. Drag hub              | 42. A/R spring pin (2)  | 70. Bottom shift spring      |
| 16. Spool cover           | 43. Right sideplate     | 71. Shift core               |
| 17. Drag seal             | 44. Right SP screw (4)  | 72. Upper shift spring       |
| 18. Spool cover screw (6) | 45. Stop cushion (2)    | 73. Handle arm bushing       |
| 19. Low speed pinion      | 46. Stop bushing (2)    | 74. Handle arm nut           |
| 20. High speed pinion     | 47. Stop screw (2)      | 75. Housing bottom screw (2) |
| 21. Pinion retainer       | 48. Button retainer (2) | 76. Release button spring    |
| 22. Bearing (7x14x5)      | 49. Button spring (2)   | 77. Shift housing bottom     |
| 23. Lever shim            | 50. Spring button (2)   | 78. Release button           |
| 24. Drag lever            | 51. Handle arm assy.    | 79. Pivot pin                |
| 25. Cam lifter            | 52. Grip assembly       | 80. Shift housing top        |
| 26. Drag cam              | 53. Grip retainer screw | 81. Housing top screw (2)    |
| 27. Cam seal              | 54. Grip cover plate    | 82. Shift push button        |
| 28. Knob spring           | 55. Rod clamp kit       |                              |