



TLW-20

TLW-20

TLW-20 Inshore Reel

Instructions For Use

Qualia Corporation

Contact Us

Parts List, Reel Schematic

396B 7th St., #164

Phone: 415-382-1099

Novato, CA 94945, USA

Email: qualia@ix.netcom.com

Prepare yourself for a pleasant surprise

This Qualia Inshore Reel is full of features you'd usually pay much more to own:

- The composite carbon frame gives you corrosion-free rigidity.
- Matching carbon sideplates offer greatest possible strength and parts alignment.
- An all aluminum anodized spool ensures strongest line support.
- All stainless steel gearing provides superior strength plus corrosion and wear resistance.
- A stainless steel foot means that your reel will always have the strongest possible attachment to your rod.
- The multi-disk carbon/stainless/Teflon drag will give you years of smooth, dependable use.
- An ON/OFF spool clicker broadcasts an audible alarm when line is being stripped from the reel.
- The comfort-touch grip keeps your hand in the fight for hour after hour of hard fishing.

So what do these specifications do for you? Truth be told, they do nothing for you until you go fishing.

But when you do go fishing with this reel, you'll find that these features give you a chance to fight harder, fight longer and fight with less fatigue.

Fish hard. Fish safe. And have fun!

CARE AND MAINTENANCE

While we have done everything possible to make your TLW-20 Reel the highest value available, it remains a finely tuned piece of equipment that requires a minimal amount of care and maintenance. We congratulate you on your excellent choice of fishing equipment and recommend that you review the following maintenance suggestions; for the longest lasting pleasure with your tackle, we suggest adding these simple procedures to your regular fishing regimen.

BEFORE EACH FISHING TRIP

Carefully consider your choice of equipment. We all know that we cannot reasonably expect a small sports car to carry the local football team to its games; every car is designed for a certain purpose. In the same way, all fishing equipment is designed for a limited set of circumstances. For the greatest fishing performance, your choice of equipment should consider the type of fishing for which it will be used.

- Check that the line on your reel is fresh. Most lines tend to stretch and degrade over time and lose both their pull test and knot strength.
- Check that the reel has been cleaned, greased and stored properly with the drag slightly loosened.
- Check that the rod guides are all in good condition (no broken or loose rings).
- Check that the rod seat holds the reel securely in place

AFTER EACH FISHING TRIP

Clean both your rod and reel, lubricate your reel carefully, and back the drag off slightly before storing your reel. This is probably the most important recommendation for maintaining the longest working life of your reel and rod.

It is not necessary to submerge your reel in fresh water or hit it with a high-pressure blast of water. Few reels are dragged through mud or keel hauled behind a boat; therefore gently spraying your reel and rod with clean water after each fishing excursion and wiping them off thoroughly with a soft towel will take care of most cleaning requirements.

After cleaning, a light coating of a thin, high grade oil on all moving parts is recommended. While we strongly recommend using a competent service technician for maintaining the insides of your reel, we know that many folks who fish enjoy disassembling their reels both for fun and for maintenance purposes. To assist those who do disassemble their reel, the attached exploded drawing should help explain the parts and assembly of your TLW-20 Reel, and to help if ordering parts is required.

ONCE EACH SEASON

If you properly maintain your reel and rod as recommended above, it is unlikely that you will ever need to send your reel in for service. Nonetheless, we recommend an occasional trip to a service center for a professional cleaning and service of your reel.

Service centers generally use better grades of grease and oil than most folks keep on hand, and it is very helpful to have a trained eye inspect your reel occasionally to make sure no unforeseen problems are developing.

If you follow the above recommendations, you should look forward to many enjoyable fishing experiences. Thank you again for your purchase of this outstanding reel.

PARTS SCHEMATIC

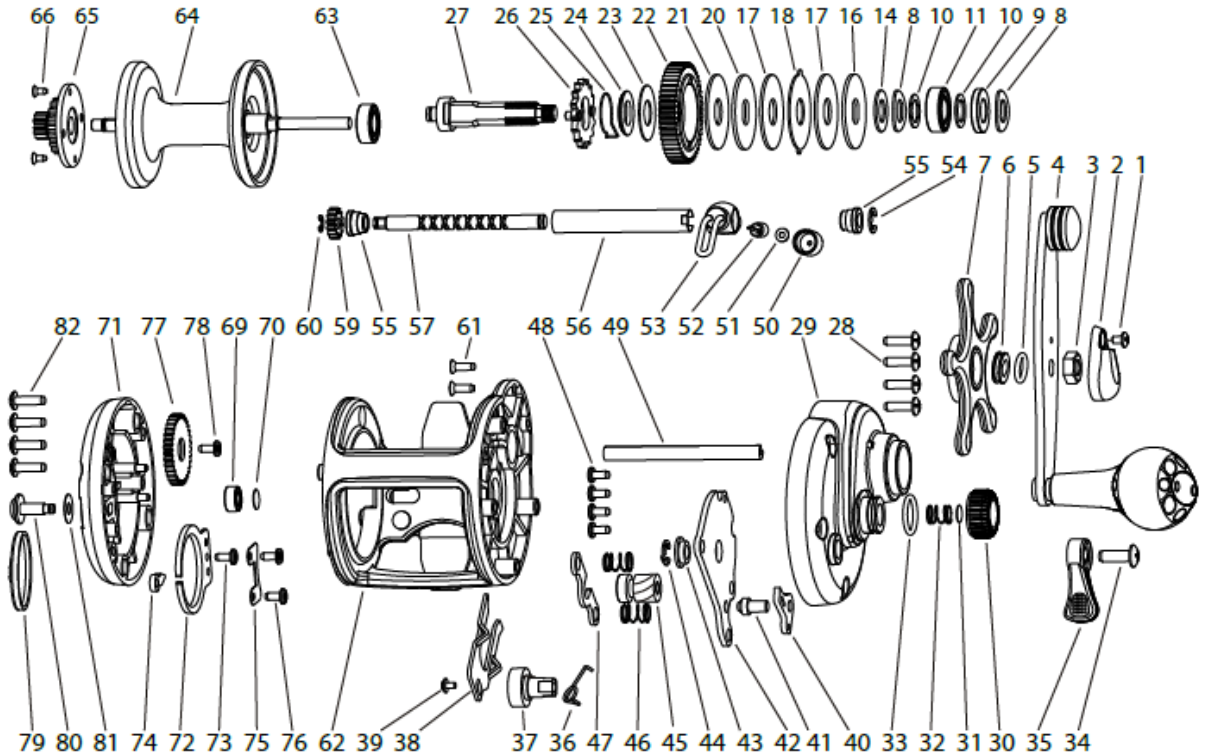

- | | | |
|------------------------------|------------------------------|-------------------------------|
| 1. Handle nut retainer screw | 31. Spacer A | 57. Lead screw |
| 2. Handle nut retainer | 32. Yoke spring A | 59. Level wind pinion |
| 3. Handle nut | 33. O-ring B | 60. Retainer clip C |
| 4. Handle assembly | 34. Clutch lever screw | 61. Frame screw (x2) |
| 5. O-ring A | 35. Clutch lever | 62. Frame |
| 6. O-ring bushing | 36. Clutch cam spring | 63. Ball bearing (7x14x5) |
| 7. Drag star | 37. Clutch cam | 64. Spool |
| 8. Drag spring | 38. Clutch plate | 65. Click gear |
| 9. POM washer | 39. Clutch plate screw | 66. Click gear screw (x2) |
| 10. Washer A | 40. A/R pawl | 69. Ball bearing (4x9x4) |
| 11. SuS bearing (8x16x5) | 41. A/R pivot pin | 70. Spacer B |
| 14. Washer B | 42. Support plate A | 71. Left sideplate |
| 16. Keyed washer A | 43. Drive shaft bushing | 72. Click spring |
| 17. Teflon washer | 44. Retainer clip A | 73. Click spring screw |
| 18. Eared washer | 45. Pinion gear | 74. Click pawl |
| 20. Keyed washer B | 46. Yoke spring B (x2) | 75. Support plate B |
| 21. Carbon fiber washer | 47. Yoke | 76. Support plate screw (x2) |
| 22. Drive gear | 48. Support plate screw (x4) | 77. Transfer gear |
| 23. Fiber washer | 49. Level wind support shaft | 78. Transfer gear screw |
| 24. Silent A/R bushing | 50. Pawl cap | 79. Name plate |
| 25. Silent A/R spring | 51. Pawl shim | 80. Click button |
| 26. Anti-reverse ratchet | 52. Level wind pawl | 81. Click button shim |
| 27. Drive shaft | 53. Line guide assembly | 82. Left sideplate screw (x4) |
| 28. Rt. sideplate screw (x4) | 54. Retainer clip B | |
| 29. Rt. sideplate | 55. Lead screw bushing (x2) | |
| 30. Spool tension knob | 56. Lead screw shield | |